

Compact hydraulic power pack type HC and HCW

Compact hydraulic power packs are a type of hydraulic power pack. They are characterised by a highly compact design, since the motor shaft of the electric motor also acts as the pump shaft.

The ready-for-connection compact hydraulic power pack type HC and HCW includes an electric drive which runs in oil. The stator is securely attached to the housing (tank). The compact hydraulic power pack is suitable for hydraulic systems with operating mode S2 or S3. The heat is dissipated via surface convection so that no external cooler is usually necessary.

A radial piston pump or external gear pump can be used as a hydraulic pump.

The compact hydraulic power pack type type HC and HCW is suitable as a highly compact control system, since connection blocks and valve banks can be directly mounted.

Features and benefits:

- Long lifetime and high pressures thanks to use of radial piston pumps
- Low oil fill volumes make it environmentally sound thanks to small amount of oil to be disposed of and low costs for hydraulic fluid
- Co-ordinated range of valves and accessories from modular system
- Suitable for vertical and horizontal installation

Intended applications:

- Clamping systems on machine tools and jigs
- Rivets and clinching equipment
- Welding robots



Nomenclature:	Radial piston or gear pump with integrated electric motor (three-phase or alternating current design)
Design:	Oil immersed hydraulic power pack for intermittent service (S3-service)
p_{max}:	Radial piston pump 700 bar Gear pump 180 bar
Q_{max}:	Radial piston pump 4.4 lpm (V _g = 1.6 cm ³ /rev) Gear pump approx. 3.4 lpm (V _g = 1.3 cm ³ /rev)
V_{usable max}:	8 l

Design and order coding example

HC24 /0,6 - A1/400 - BWH1F-HH-1-1-G24 - 400V 50 Hz

Motor voltage 3 ~ 400V 50 Hz, 3 ~ 460V 60 Hz
1 ~ 230V 50 Hz, 1 ~ 110V 60 Hz (3~phase motor)

Optional directly mounted directional valve bank

Connection block

Pump version

Single circuit pump

- Radial piston pump H (3-, 5- or 6-cylinders)
oder Gear pump Z

Basic type, size

Type HC (3-phase motor) and type HCW (single-phase-motor, power reduction of 30 ... 50% depending on size), size 1 to 2, type HCG (direct current motor), size 1

- Lying at low installation Heights (Model HC..L)
- Alternative standing version
- Usable volume V_{usable} 0.5 l to 1.5 l
- With/without fluid level gauge
- With DC-motor (Type HCG) for short time operation

Function

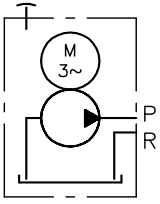

Example circuit:

HC 24/0.64

Pump unit type HC, size 24, pump delivery flow approx. 0.64 lpm

- A1/400

Connection block type A and pressure-limiting valve (400 bar)

- BWH1F - RH1 - 1 - 1 - G 24

Directly mounted valve bank type BWH 1

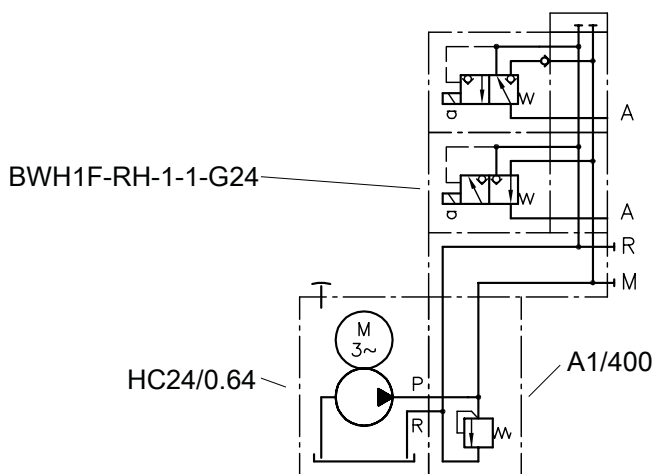

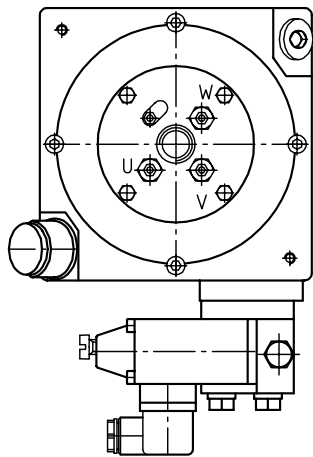
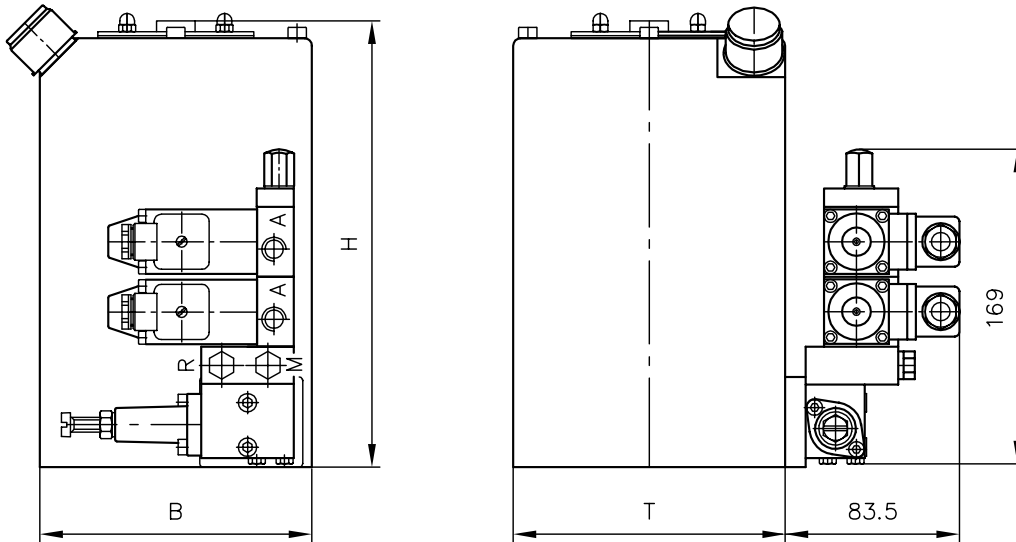
General parameters and dimensions

	Radial piston pump (3 cylinders)			Gear pump			P_N [kW] ¹⁾	m [kg] ²⁾	Dimensions [mm]		
	Max. pressure	Delivery flow		Max. pressure	Delivery flow				H	B	T
	p_{max} [bar]	Q_{pu} [lpm] 50 Hz	Q_{pu} [lpm] 60 Hz	p_{max} [bar]	Q_{pu} [lpm] 50 Hz	Q_{pu} [lpm] 60 Hz					
HC 14	700 - 160	0.2 - 1.05	0.2 - 1.2	-	-	-	0.18	6.3	197	120	120
HC 12	600 - 120	0.4 - 2.15	0.5 - 2.5	-	-	-	0.25				
HC 24	700 - 185	0.27 - 2.27	0.3 - 2.7	150	0.4 - 1.6	0.5 - 1.9	0.55	10.1	243	148	148
HC 22	700 - 140	0.52 - 4.41	0.6 - 5.3	150	0.9 - 3.4	1.1 - 4	0.55				

 1) The actual power consumption depends on the respective operation pressure and can be up to $1.5 \times P_N$

2) Without oil filling

Circuit example:

HC 24/0.64 - A2/400
- BWH 1 F 1-DH3 R/230-33-G24
- 3x400V 50Hz

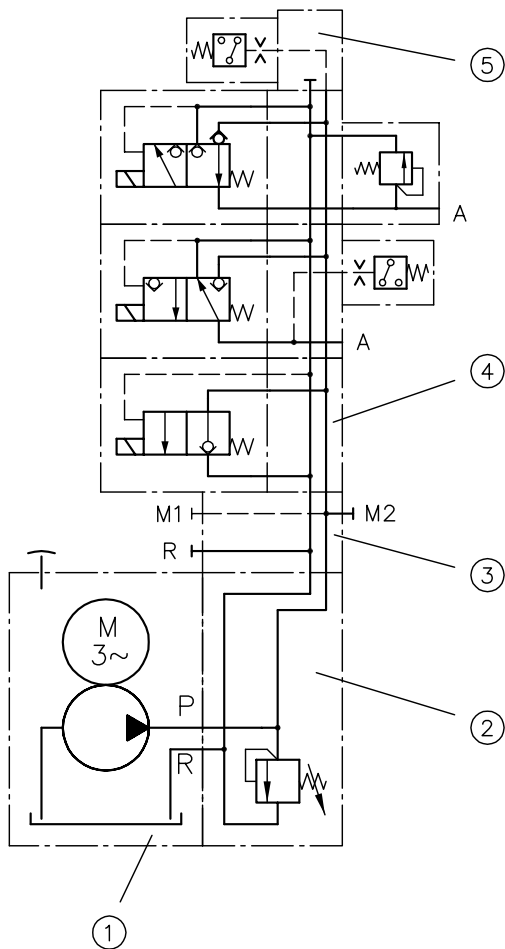

- 1 Compact hydraulic power pack
- 2 Connection block
- 3 Adapter plate
- 4 Valve section
- 5 End plate

Associated technical data sheets:

- [Compact hydraulic power pack type HC and HCW: D 7900](#)
- [Compact hydraulic power pack type HCG: D 7900 G](#)

Connection blocks:

- Type A, B and C: [D 6905 A/1](#), [D 6905 B](#), [D 6905 C](#)

Directly mountable valve banks:

- [Valve bank \(directional seated valve\) type VB: D 7302](#)
- [Valve bank \(directional seated valve\) type BWN and BWH: D 7470 B/1](#)

Directly mountable valve banks:

- [Valve bank \(nominal size 6\) type BA: D 7788](#)
- [Valve bank \(directional seated valve\) type BVH: D 7788 BV](#)